

# OPERATION MANUAL

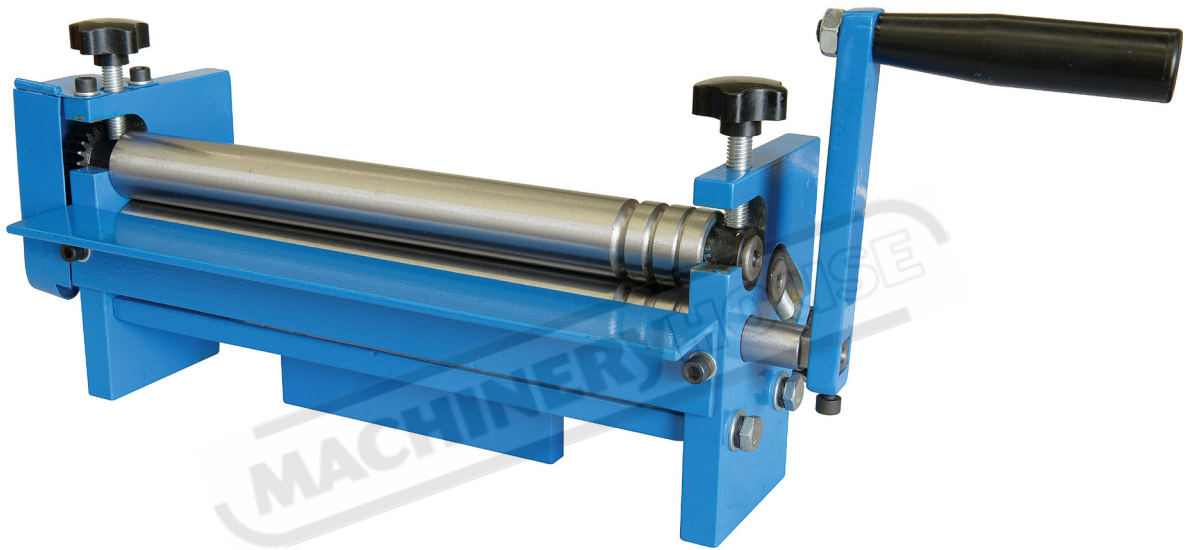

## Manual Sheet Metal Curving Rolls

**Model. SRG-12**

Order Code S267

*Edition No : SRG-12-1*

*Date of Issue : 05/2021*

**MACHINE DETAILS**

<b>MACHINE</b>	<input type="text" value="Manual Sheet Metal Curving Rolls"/>
<b>MODEL NO.</b>	<input type="text" value="SRG-12"/>
<b>SERIAL NO.</b>	<input type="text"/>
<b>DATE OF MANF.</b>	<input type="text"/>

DISTRIBUTED BY



[www.machineryhouse.com.au](http://www.machineryhouse.com.au)  
[www.machineryhouse.co.nz](http://www.machineryhouse.co.nz)

**NOTE:**

This manual is only for your reference. Owing to the continuous improvement of the Hafco Metalmaster machine, changes may be made at any time without obligation or notice. Please ensure the local voltage is the same as listed on the specification plate before operating this electric machine.



**NOTE:**

In order to see the type and model of the machine, please see the specification plate. Usually found on the back of the machine. See example (Fig.1)

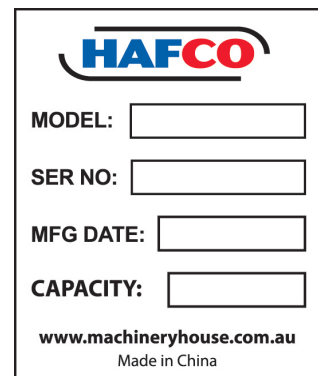

FIG.1

**SPECIFICATION**

Order Code	S267
<b>MODEL</b>	<b>SRG-12</b>
Useful Length (mm)	305
Capacity - Mild Steel (mm)	1
Roll Diameter (mm)	48
Includes Stand (Yes/ No)	No
Wire Groove Positions (No)	3
Dimensions (L x W x H) (cm)	75 x 19.5 x 39.3
Shipping Dimensions (L x W x H) (cm)	42.5 x 18 x 20.5
Nett Weight (kg)	13.6

**IDENTIFICATION**

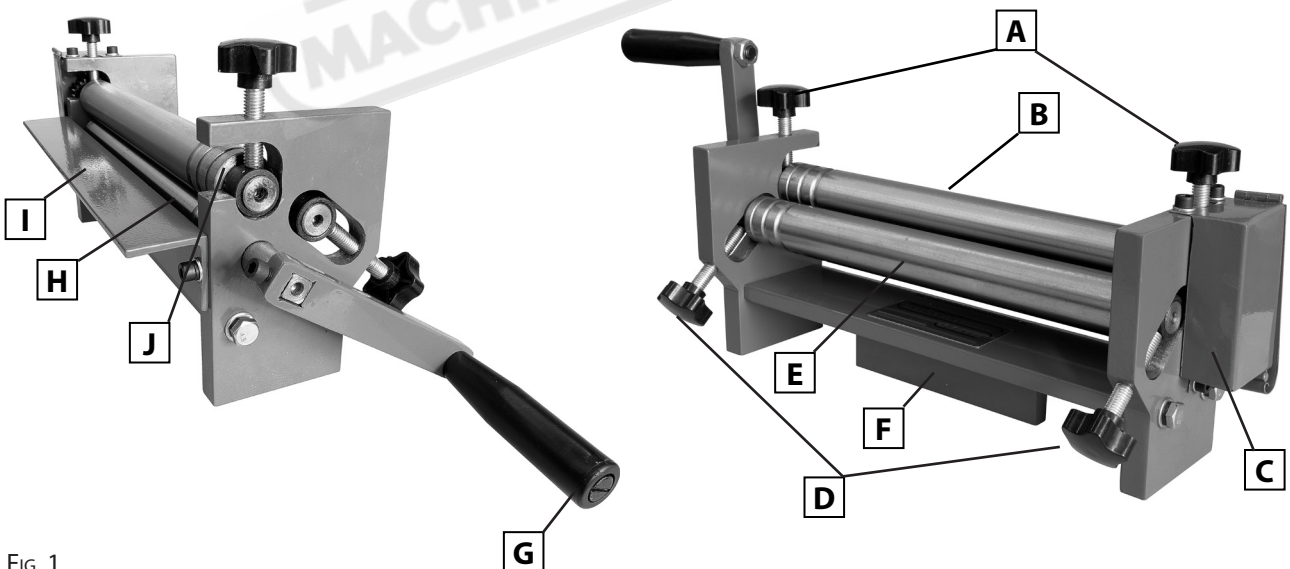

FIG. 1

<b>A</b>	Thickness Adjustment Knobs	<b>F</b>	Vise Lug
<b>B</b>	Upper Roller	<b>G</b>	Crank Handle
<b>C</b>	Gear Guard	<b>H</b>	Lower Roller
<b>D</b>	Radius Adjustment Knobs	<b>I</b>	Workpiece Support
<b>E</b>	Rear Roller	<b>J</b>	Upper Roller Access Slot

**GENERAL MACHINE SHOP SAFETY WARNINGS AND PRECAUTIONS**

**⚠ WARNING** *When using this tool, basic safety precautions should always be followed to reduce the risk of personal injury and damage. Read all instructions before using this tool!*

1. **Keep the work area clean.** Cluttered areas invite injuries.
2. **Observe work area conditions.** Do not use machines or power tools in damp or wet locations. Do Not expose to rain. Keep work area well lite. Do not use electrically powered tools in the presence of flammable gases or liquids.
3. **Keep children away.** Children must never be allowed in the work area. Do not let them handle machines, tools, or extension cords.
4. **Store idle equipment.** When not in use, tools must be stored in a dry location to inhibit rust. Always lock up tools and keep out of reach of children.
5. **Do not force tool.** It will do the job better and more safely at the rate for which it was intended. Do not use inappropriate attachments in an attempt to exceed the tool capacity.
6. **Use the right tool for the job.** Do not attempt to force a small tool or attachment to do the work of a larger industrial tool. Do not modify this tool and do not use this tool for a purpose for which it was not intended.
7. **Dress properly.** Do not wear loose clothing or jewelry as they can be caught in moving parts. Protective, electrically non-conductive clothes and non-skid footwear are recommended when working. Wear restrictive hair covering to contain long hair.
8. **Use eye and ear protection.** Always wear ANSI approved impact safety goggles. Wear a full face shield if you are producing metal filings or wood chips. Wear an ANSI approved dust mask or respirator when working around metal, wood, and chemical dusts and mists.
9. **Do not overreach.** Keep proper footing and balance at all times. Do not reach over or across running machines. Keep hands and fingers clear of the Rolls when operating.
10. **Maintain tools with care.** Keep tools sharp and clean for better and safer performance. Follow instructions for lubricating and changing accessories. Inspect tool cords periodically and, if damaged, have them repaired by an authorized technician. The handle must be kept clean, dry, and free from oil and grease at all times.
11. **Remove adjusting keys and wrenches.** Check that keys and adjusting wrenches are removed from the tool or machine work surface before operating.
12. **Stay alert.** Watch what you are doing, use common sense. Do not operate any tool when you are tired.
13. **Check for damaged parts.** Before using any tool, any part that appears damaged should be carefully checked to determine that it will operate properly and perform its intended function. Check for alignment and binding of moving parts; any broken parts or mounting fixtures; and any other condition that may affect proper operation. Any part that is damaged should be properly repaired or replaced by a qualified technician. Do not use the tool if any switch does not turn on and off properly.
14. **Replacement parts and accessories.** When servicing, use only identical replacement parts. Use of any other parts will void the warranty. Only use accessories intended for use with this tool.

**GENERAL MACHINE SHOP SAFETY WARNINGS AND PRECAUTIONS**

- 15. Do not operate tool if under the influence of alcohol or drugs.** Read warning labels if taking prescription medicine to determine if your judgment or reflexes are impaired while taking drugs. If there is any doubt, do not operate the tool.
- 16. Maintenance.** For your safety, service and maintenance should be performed regularly by a qualified technician.
- 17. Workpiece may be sharp.** After bending or cutting workpieces use caution. Be aware of sharp edges or sharp shreds of metal that may be created. Use heavy duty gloves when handling the workpiece.

 **WARNING** *The warnings, cautions, and instructions discussed in this instruction manual cannot cover all possible conditions and situations that may occur. It must be understood by the operator that common sense and caution are factors which cannot be built into this product, but must be supplied by the operator.*

**HAZARDS ASSOCIATED WITH MACHINES include, but are not limited to:**

- Being struck by ejected parts of the machinery
- Being struck by material ejected from the machinery
- Contact or entanglement with the machinery
- Contact or entanglement with any material in motion

**Health Hazards** (other than physical injury caused by moving parts)

- Chemicals hazards that can irritate, burn, or pass through the skin
- Airborne items that can be inhaled, such as oil mist, metal fumes, solvents, and dust
- Heat, noise, and vibration
- Ionizing or non-ionizing radiation (X-ray, lasers, etc.)
- Biological contamination and waste
- Soft tissue injuries (for example, to the hands, arms, shoulders, back, or neck) resulting from repetitive motion, awkward posture, extended lifting, and pressure grip)

**Other Hazards**

- Slips and falls from and around machinery during maintenance
- Unstable equipment that is not secured against falling over
- Safe access to/from machines (access, egress)
- Fire or explosion
- Pressure injection injuries from the release of fluids and gases under high pressure
- Electrical Hazards, such as electrocution from faulty or ungrounded electrical components
- Environment in which the machine is used (in a machine shop, or in a work site)

**ADDITIONAL SAFETY FOR MANUAL BENDING ROLLS**

**DO NOT** use this machine unless you have been instructed in its safe use and operation and have read and understood this manual



*Safety glasses must be worn when operating this equipment*



*Long and loose hair must be contained when operating this equipment.*



*Safety footwear must be worn when operating this equipment*



*Close fitting/protective clothing must be worn when operating the machine*



*Dust mask must be worn when operating in high dust areas.*



*Hearing protection must be used when operating in a noisy environment*

**PRE-OPERATIONAL SAFETY CHECKS**

- ✓ Locate and ensure you are familiar with all machine operations and controls.
- ✓ Ensure all guards are fitted, secure and functional. Do not operate if guards are missing or faulty.
- ✓ Working parts should be well lubricated and the rolls free of rust and dirt.
- ✓ Check workspaces and walkways to ensure no slip/trip hazards are present.
- ✓ Be aware of other people in the area and ensure the area is clear before using equipment.

**OPERATIONAL SAFETY CHECKS**

- ✓ Adjust both ends of the rollers evenly.
- ✓ Take care during the initial feeding of the workpiece into the rolls.
- ✓ Hold the workpiece sufficiently far back from the edge being fed into the rolls, to allow for the in-feed speed of the machine.
- ✓ Wind handle at a slow even rate. Be aware of rotating rollers.
- ✓ Only one person may operate this machine at any one time.

**ENDING OPERATIONS AND CLEANING UP**

- ✓ Ensure the handle is left in a safe position after use.
- ✓ Leave the work area in a safe, clean and tidy state.

**DON'T**

- ✗ Do not use faulty equipment. Immediately report suspect machinery.
- ✗ Do not attempt to roll material beyond the capacity of the machine.
- ✗ Do not attempt to bend rod or wire in bending rolls unless the rolls are grooved for this purpose.

**POTENTIAL HAZARDS AND INJURIES**

- Sharp edges and burrs.
- Crush and pinch points.
- Hair/clothing getting caught in moving machine parts.
- Operator's hands may be caught and drawn into the counter-rotating rollers.



## 4 SETUP

### UNPACKING

This machine was carefully packaged for safe transport. When unpacking, separate all enclosed items from packaging materials and inspect them for shipping damage. If items are damaged, please contact your distributor.

**NOTE:** *Save all the packaging materials until you are completely satisfied with the machine and have resolved any issues with the distributor, or the shipping agent.*

When unpacking, check the packing list to make sure that all parts shown are included. If any parts are missing or broken, please contact the your distributor.

### CLEAN - UP

The unpainted surfaces of the machine have been coated with a waxy oil to protect them from corrosion during shipment. Remove the protective coating with a solvent cleaner or a citrus based degreaser.

Optimum performance from your machine will be achieved when you clean all moving parts or sliding contact surfaces that are coated with rust prevented products.

It is advised to avoid chlorine based solvents, such as acetone or brake parts cleaner, as they will damage painted surfaces and strip metal should they come in contact. Always follow the manufacturer's instructions when using any type of cleaning product.

### SITE PREPARATION

When selecting the site for the machine, consider the largest size of workpiece that will be processed through the machine and provide enough space around the machine for operating the machine safely. Consideration should be given to the installation of auxiliary equipment. Leave enough space around the machine to open or remove doors/covers as required for the maintenance and service as described in this manual.

It is recommended that the machine is anchored to the floor to prevent tipping or shifting. It also reduces vibration that may occur during operation.

### MOUNTING IN VISE

There are substantial forces exerted on the metal curving rolls during operation. With this in mind, the curving roll must be firmly secured in a vise that is solidly attached to a workbench that will support the weight and dynamic forces of the operation. (Fig. 2)

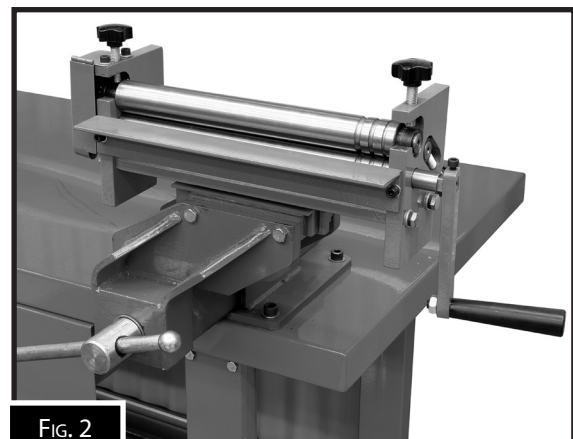

FIG. 2

**5. OPERATION**

This machine may perform many types of operations that are beyond the scope of this manual. Many of these operations may be dangerous or deadly if performed incorrectly. The instructions in this section are written with the understanding that the operator has the necessary knowledge and skills to operate this machine. If at any time you are experiencing difficulties performing any operation, stop using the machine!

If you are an inexperienced operator, we strongly recommend that you read books, trade articles, or seek training from an experienced operator before performing any unfamiliar operations. **Above all, your safety should come first!**

**Thickness Adjustment Knob.** Raises and lowers the upper roller to adjust for the thickness of different workpieces. (Fig. 3)

**Radius Adjustment Knob.** Raises and lowers the rear roller to create smaller and larger radius bends. (Fig. 3)

**Hand Crank:** Rotates the rollers to feed the workpiece through the machine. (Fig. 3)

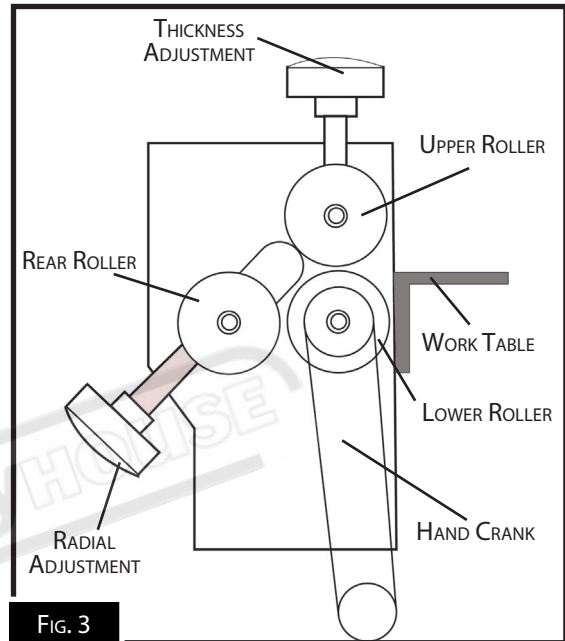

FIG. 3

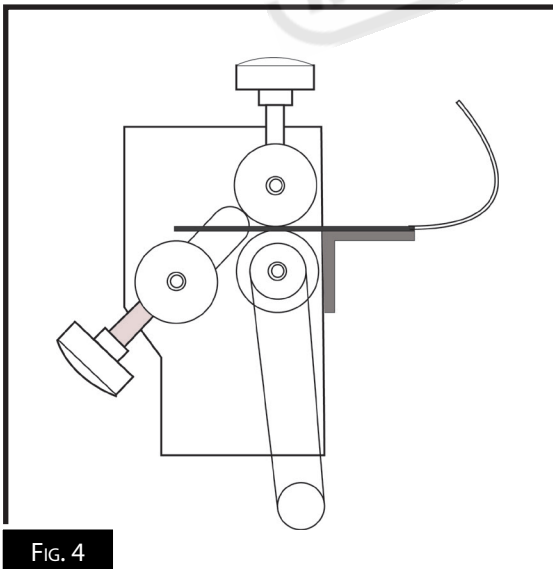

FIG. 4

**CURVE ROLLING (FIG.5)**

Use the thickness adjustment knobs to adjust the height so that you can place the workpiece between the rollers. Rotate the radius adjustment knobs counterclockwise to raise the rear roller

**FLAT ROLLING (FIG.4)**

Lower the rear roller below the workpiece path. This will prevent the rear roller from bending a curve in the workpiece as it is fed through the slip roll.

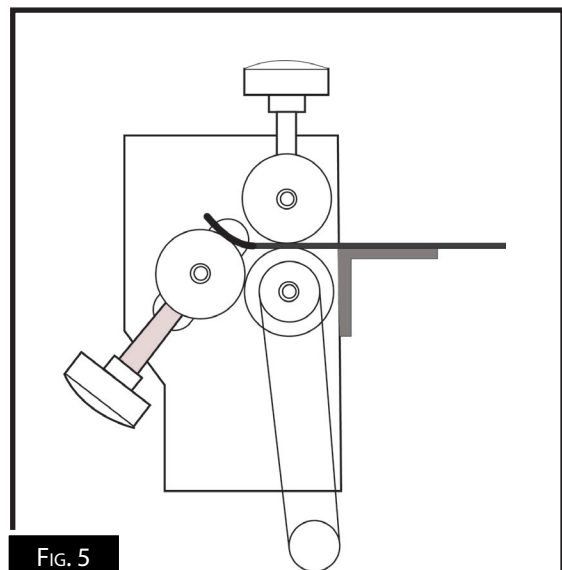

FIG. 5



# SPARE PARTS SECTION

## Manual Sheet Metal Curving Rolls

**Model. SRG-12**

Order Code S267

*Edition No* : SRG-12-1

*Date of Issue* : 05/2021

The following section covers the spare parts diagrams and lists that were current at the time this manual was originally printed. Due to continuous improvements of the machine, changes may be made at any time without notification.

### HOW TO ORDER SPARE PARTS

1. Have your machines **model number, serial number & date of manufacture** on hand, these can be found on the specification plate mounted on the machine
2. A scanned copy of your parts list/diagram with required spare part/s identified
3. Go to [www.machineryhouse.com.au/contactus](http://www.machineryhouse.com.au/contactus) and fill out the enquiry form attaching a copy of scanned parts list.

### CONTENTS

Spare Parts Diagram.....	10
Sparts Parts List .....	11

**SPARE PARTS DIAGRAM**

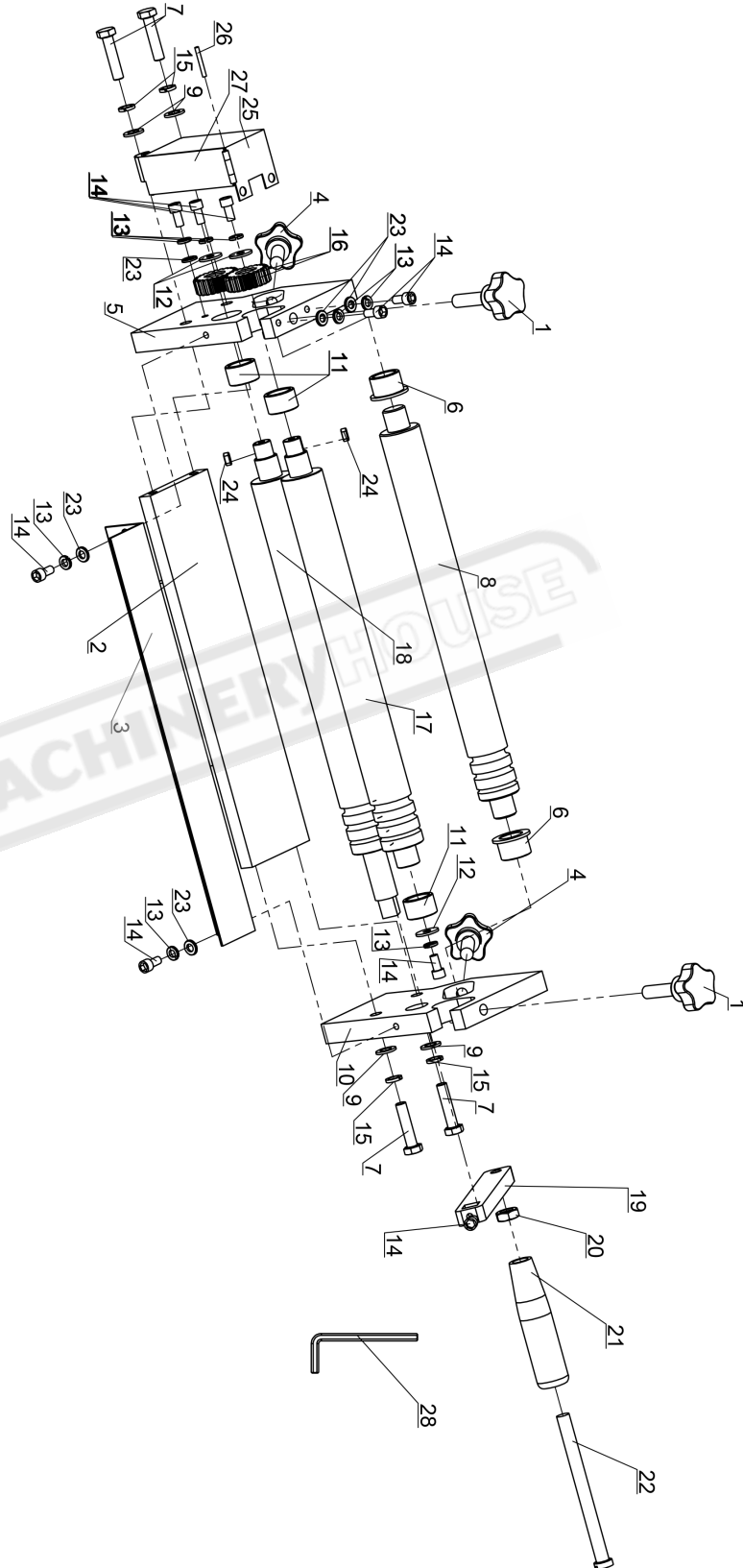

**SPARE PARTS LIST**

ITEM	DESCRIPTION	QTY.	ITEM	DESCRIPTION	QTY.
1	ADJUSTMENT KNOB	2	15	SPRING WASHER 8MM	4
2	BASE	1	16	GEAR	2
3	GUIDE PLATE	1	17	UPPER SHAFT	1
4	ADJUSTMENT KNOB	2	18	LOWER SHAFT	1
5	LEFT STAND	1	19	HANDLE	1
6	BUSHING	2	20	NUT M10	1
7	BOLT M8X35	4	21	HANDLE GRIP	1
8	IDLE SHAFT	1	22	SCREW M10X120	1
9	WASHER 8MM	4	23	WASHER 6MM	5
10	RIGHT STAND	1	24	KEY	2
11	BUSHING	3	25	GEAR COVER	1
12	WASHER 6MM	3	26	PIN	1
13	SPRING WASHER 6MM	8	27	COVER	1
14	SCREW M6X12	9	28	HEX KEY WRENCH 5MM	1

**NOTE: SOME INDIVIDUAL PARTS MAY ONLY BE AVAILABLE AS AN ASSEMBLY**

# WARNING

## General Machinery Safety Instructions

---

Machinery House  
requires you to read this entire Manual before using this machine.

- 1. Read the entire Manual before starting machinery.** Machinery may cause serious injury if not correctly used.
- 2. Always use correct hearing protection when operating machinery.** Machinery noise may cause permanent hearing damage.
- 3. Machinery must never be used when tired, or under the influence of drugs or alcohol.** When running machinery you must be alert at all times.
- 4. Wear correct Clothing.** At all times remove all loose clothing, necklaces, rings, jewelry, etc. Long hair must be contained in a hair net. Non-slip protective footwear must be worn.
- 5. Always wear correct respirators around fumes or dust when operating machinery.** Machinery fumes & dust can cause serious respiratory illness. Dust extractors must be used where applicable.
- 6. Always wear correct safety glasses.** When machining you must use the correct eye protection to prevent injuring your eyes.
- 7. Keep work clean and make sure you have good lighting.** Cluttered and dark shadows may cause accidents.
- 8. Personnel must be properly trained or well supervised when operating machinery.** Make sure you have clear and safe understanding of the machine you are operating.
- 9. Keep children and visitors away.** Make sure children and visitors are at a safe distance for you work area.
- 10. Keep your workshop childproof.** Use padlocks, Turn off master power switches and remove start switch keys.
- 11. Never leave machine unattended.** Turn power off and wait till machine has come to a complete stop before leaving the machine unattended.
- 12. Make a safe working environment.** Do not use machine in a damp, wet area, or where flammable or noxious fumes may exist.
- 13. Disconnect main power before service machine.** Make sure power switch is in the off position before re-connecting.
- 14. Use correct amperage extension cords.** Undersized extension cords overheat and lose power. Replace extension cords if they become damaged.
- 15. Keep machine well maintained.** Keep blades sharp and clean for best and safest performance. Follow instructions when lubricating and changing accessories.
- 16. Keep machine well guarded.** Make sure guards on machine are in place and are all working correctly.
- 17. Do not overreach.** Keep proper footing and balance at all times.
- 18. Secure workpiece.** Use clamps or a vice to hold the workpiece where practical. Keeping the workpiece secure will free up your hand to operate the machine and will protect hand from injury.
- 19. Check machine over before operating.** Check machine for damaged parts, loose bolts, Keys and wrenches left on machine and any other conditions that may effect the machines operation. Repair and replace damaged parts.
- 20. Use recommended accessories.** Refer to instruction manual or ask correct service officer when using accessories. The use of improper accessories may cause the risk of injury.
- 21. Do not force machinery.** Work at the speed and capacity at which the machine or accessory was designed.
- 22. Use correct lifting practice.** Always use the correct lifting methods when using machinery. Incorrect lifting methods can cause serious injury.
- 23. Lock mobile bases.** Make sure any mobile bases are locked before using machine.
- 24. Allergic reactions.** Certain metal shavings and cutting fluids may cause an allergic reaction in people and animals, especially when cutting as the fumes can be inhaled. Make sure you know what type of metal and cutting fluid you will be exposed to and how to avoid contamination.
- 25. Call for help.** If at any time you experience difficulties, stop the machine and call you nearest branch service department for help.

# WARNING

## Manual Sheetmetal Rolls Safety Instructions

---

Machinery House  
requires you to read this entire Manual before using this machine.

- 1. Maintenance.** Make sure all moving parts are locked down before any inspection, adjustment or maintenance is carried out.
- 2. Rolling machine Condition.** Rolling machine must be maintained for a proper working condition. Never operate a Rolling machine that has damaged or worn parts. Scheduled routine maintenance should be performed on a scheduled basis.
- 3. Roll Condition.** Never operate a Rolling machine with a damaged or badly worn Rolls. Replace if required. Rolls should never be greased or lubricated as rolls will slip the material and will not bend.
- 4. Hand Hazard.** Keep hands and fingers clear from moving parts. Serious injury can occur if hand or finger tips get pinched by rolls and can be dragged into machine.
- 5. Gloves & Glasses.** Always wear leather gloves and approved safety glasses when using this machine.
- 6. Avoiding Entanglement.** Rolling machine guards must be used at all times. Tie up long hair and use the correct hair nets to avoid any entanglement with the Rolling machine moving parts.
- 7. Understand the machines controls.** Make sure you understand the use and operation of all controls.
- 8. Work area hazards.** Keep the area around the Rolling machine clean from oil, tools, chips. Pay attention to other persons in the area and know what is going on around the area to ensure unintended accidents.
- 9. Guards.** Do not operate this machine without the correct guards in place. Necessary guards protect you from injuries by rolls and moving gears and parts.
- 10. Material condition.** Material must be clean out of oil and dry. Oily material can slip and will not bend.
- 11. Material hardness.** Make sure your hardness is the same throughout the material, we recommend that you use certified material. Never bend hard steel, glass or fragile material on this machine.
- 12. Level machine.** Level the machine on a flat concrete surface by using a spirit level.
- 13. Feeding material.** Making a tight bend in one pass is not possible. So you need several passes before you can achieve a certain radius. Tighter curves and full radius always need more passes.
- 14. Call for help.** If at any time you experience difficulties, stop the machine and call your nearest branch service department for help.

# PLANT SAFETY PROGRAM

## **NEW MACHINERY HAZARD IDENTIFICATION, ASSESSMENT & CONTROL**

### **Manual Sheetmetal Rolls**

Developed in Co-operation Between A.W.I.S.A and Australia Chamber of Manufactures  
 This program is based upon the Safe Work Australia, Code of Practice - Managing Risks of Plant in the Workplace ( WHSA 2011 No10 )



Item No.	Hazard Identification	Hazard Assessment	Risk Control Strategies <small>(Recommended for Purchase / Buyer / User)</small>
B	CRUSHING	LOW	Secure & support work material. Ensure machine is bolted down.
C	CUTTING, STABBING, PUNCTURING	MEDIUM	Wear gloves to prevent cuts from sharp material.
D	SHEARING	MEDIUM	Keep hands clear from moving parts on rolls.
Plant Safety Program to be read in conjunction with manufactures instructions			



[www.machineryhouse.com.au](http://www.machineryhouse.com.au)



[www.machineryhouse.co.nz](http://www.machineryhouse.co.nz)

Authorised and signed by:  
 Safety officer:   
 Manager: 

Revised Date: 12th March 2012